

E58 Series

Ø58mm Incremental Rotary Encoder

■ Features

[Totem pole, NPN open collector, Voltage, Line driver output type]

- Ø58mm flange type
- Suitable for measuring angle, position, revolution, speed, acceleration and distance
- Power supply: 5VDC, 12-24VDC ±5%



[Analog sine wave OP Amp output type]

- Taper shaft
- Analog sine wave OP Amp output
- Power supply: 5VDC ±5%



⚠ Please read "Safety Considerations" in operation manual before using.



■ Ordering Information

E58SC	10	8000	3	N	24		
Series (Ø58mm)	Shaft diameter		Pulses/revolution	Output phase	Control output	Power supply	Cable ^{※1}
SC: Shaft Clamping	External	10	Refer to resolution	2: A, B 3: A, B, Z 4: A, \bar{A} , B, \bar{B} 6: A, \bar{A} , B, \bar{B} , Z, \bar{Z}	T: Totem pole output N: NPN open collector output V: Voltage output L: Line driver output	5: 5VDC ±5% 24: 12-24VDC ±5%	No mark : Axial/Radial cable type C: Axial/Radial cable connector type CR: Axial connector type CS: Radial connector type
SS: Shaft Synchro		6					
H: Hollow shaft	Inner	12	Refer to resolution	10: A, \bar{A} , B, \bar{B} , Z, \bar{Z} , C, \bar{C} , D, \bar{D}	A: Analog sine wave OP Amp output	5: 5VDC ±5%	R: Axial cable type S: Radial cable type
HB: Blind hollow shaft							
S: Shaft	External	Ø9.25mm	2048				

※1: Please refer to 'connection' in the specifications for the detailed information about cable.

Incremental Ø58mm Shaft/Hollow Shaft/Blind Hollow Shaft Type

Shaft Type/Hollow Shaft Type/Blind Hollow Shaft Type Ø58mm Incremental Rotary Encoder

Specifications

Item		Shaft Type/Hollow Shaft Type/Blind Hollow Shaft Type Ø58mm Incremental Rotary Encoder		
Resolution (PPR) ^{※1}		*1, *2, *5, 10, *12, 15, 20, 23, 25, 30, 35, 40, 45, 50, 60, 75, 100, 120, 125, 150, 192, 200, 240, 250, 256, 300, 360, 400, 500, 512, 600, 800, 1000, 1024, 1200, 1500, 1800, 2000, 2048, 2500, 3000, 3600, 5000, 6000, 8000		
Electrical specification	Output phase	A, B, Z phase (line driver output: A, Ā, B, B̄, Z, Z phase)		
	Phase difference of output	Output between A and B phase: $\frac{T}{4} \pm \frac{T}{8}$ (T=1 cycle of A phase)		
	Control output	Totem pole output	<ul style="list-style-type: none"> • [Low] - Load current: max. 30mA, residual voltage: max. 0.4VDC= • [High] - Load current: max. 10mA, output voltage (power voltage 5VDC=): min. (power voltage-2.0)VDC=, output voltage (power voltage 12-24VDC=): min. (power voltage-3.0)VDC= 	
		NPN open collector output	Load current: max. 30mA, residual voltage: max. 0.4VDC=	
		Voltage output	Load current: max. 10mA, residual voltage: max. 0.4VDC=	
		Line driver output	<ul style="list-style-type: none"> • [Low] - Load current: max. 20mA, residual voltage: max. 0.5VDC= • [High] - Load current: max. -20mA, output voltage (power voltage 5VDC=): min. 2.5VDC=, output voltage (power voltage 12-24VDC=): min. (power voltage-3.0)VDC= 	
	Response time (rise, fall)	Totem pole output	Max. 1μs (cable length: 2m, I sink = 20mA)	
		NPN open collector output		
		Voltage output		
		Line driver output		
	Max. response frequency	300kHz		
	Power supply	<ul style="list-style-type: none"> • 5VDC= ±5% (ripple P-P: max. 5%) • 12-24VDC= ±5% (ripple P-P: max. 5%) 		
	Current consumption	Max. 80mA (disconnection of the load), Line driver output: max. 50mA (disconnection of the load)		
	Insulation resistance	Over 100MΩ (at 500VDC megger between all terminals and case)		
Dielectric strength	750VAC 50/60Hz for 1 min (between all terminals and case)			
Connection	<ul style="list-style-type: none"> • SC/SS/HB type: axial cable type, axial cable connector type, axial/radial connector type • H type: radial cable type, radial cable connector type 			
Mechanical specification	Starting torque	<ul style="list-style-type: none"> • SC/SS type: max. 40gf·cm (0.004N·m) • H/HB type: max. 90gf·cm (0.009N·m) 		
	Moment of inertia	<ul style="list-style-type: none"> • SC/SS type: max. 15g·cm² (1.5×10⁻⁶ kg·m²) • H/HB type: max. 20g·cm² (2×10⁻⁶ kg·m²) 		
	Shaft loading	<ul style="list-style-type: none"> • SC/SS type-Radial: max. 10kgf, Thrust: max. 2.5kgf • H/HB type-Radial: max. 2kgf, Thrust: max. 1kgf 		
	Max. allowable revolution ^{※2}	5,000rpm		
Vibration	1.5mm amplitude at frequency of 10 to 55Hz (for 1 min) in each X, Y, Z direction for 2 hours			
Shock	Approx. max. 75G			
Environment	Ambient temperature	-10 to 70°C, storage: -25 to 85°C		
	Ambient humidity	35 to 85%RH, storage: 35 to 90%RH		
Protection structure	IP50 (IEC standard)			
Cable	Ø5mm, 5-wire (line driver output: 8-wire), 2m, Shield cable (AWG24, core diameter: 0.08mm, number of cores: 40, insulator out diameter: Ø1mm)			
Accessory	Coupling (SC type: Ø10mm, SS type: Ø6mm), Bracket			
Approval	CE (except for line driver output)			
Weight ^{※3}	Cable type, Cable connector type	<ul style="list-style-type: none"> • SC type: approx. 420g (approx. 310g) • H/HB type: approx. 380g (approx. 270g) 	<ul style="list-style-type: none"> • SS type: approx. 395g (approx. 285g) 	
	Connector type	<ul style="list-style-type: none"> • SC type: approx. 340g (approx. 230g) • HB type: approx. 310g (approx. 200g) 	<ul style="list-style-type: none"> • SS type: approx. 315g (approx. 205g) 	

※1: ** pulse is only for A, B phase. (line driver output is for A, Ā, B, B̄ phase) [In case of hollow shaft type, 6000, 8000 PPR excluded] Not indicated resolutions are customizable.

※2: Make sure that max. response revolution should be lower than or equal to max. allowable revolution when selecting the resolution.

$$[\text{Max. response revolution (rpm)}] = \frac{\text{Max. response frequency}}{\text{Resolution}} \times 60 \text{ sec}$$

※3: The weight includes packaging. The weight in parenthesis is for unit only.

※Environment resistance is rated at no freezing or condensation.

SENSORS

CONTROLLERS

MOTION DEVICES

OTHERS

(A) Photoelectric Sensors

(B) Fiber Optic Sensors

(C) Door/Area Sensors

(D) Vision Sensors

(E) Proximity Sensors

(F) Pressure Sensors

(G) Rotary Encoders

(H) Connectors/ Connector Cables/ Sensor Distribution Boxes/ Sockets

E58 Series

Control Output Diagram

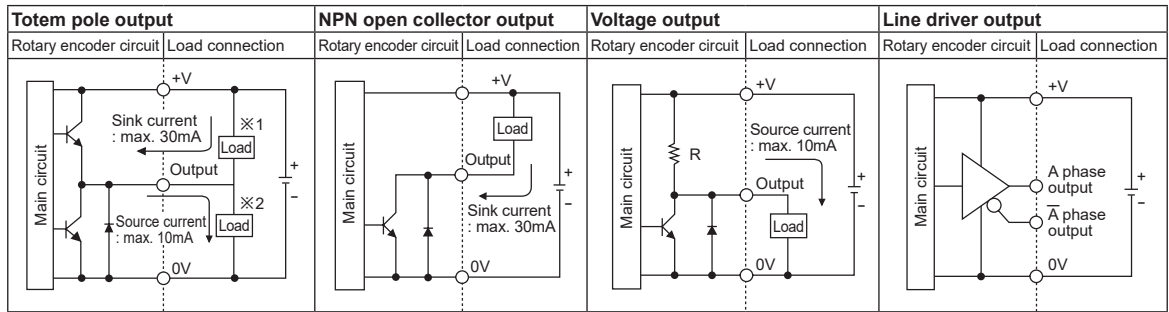

- All output circuits of A, B, Z phase are same. (line driver output is A, \bar{A} , B, \bar{B} , Z, \bar{Z})
- Totem pole output type can be used for NPN open collector type (※1) or voltage output type (※2).

Output Waveforms

Totem pole output / NPN open collector output / Voltage output

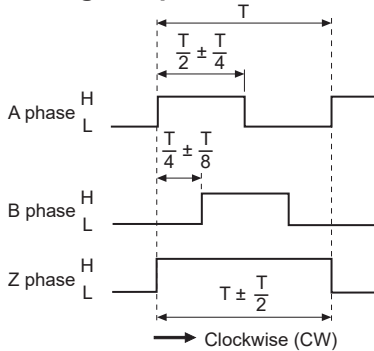

Line driver output

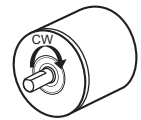
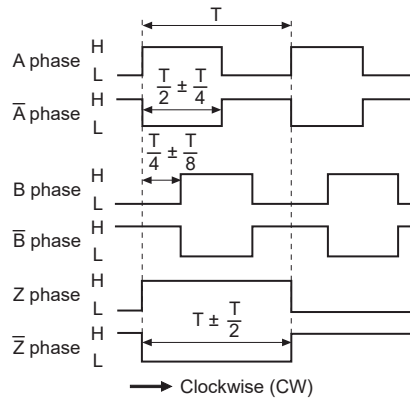

Connections

Axial/Radial cable type

- Totem pole output / NPN open collector output / Voltage output

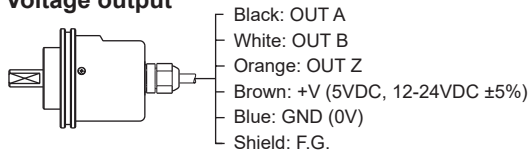

- Line driver output

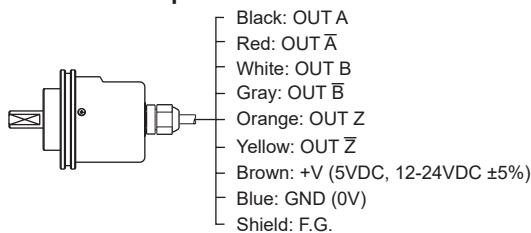

- ※ Unused wires must be insulated.
- ※ The metal cable and shield cable of encoder should be grounded (F.G.)
- ※ Do not apply tensile strength over 30N to the cable.

Axial/Radial cable connector type / Axial/Radial connector type

- Totem pole output / NPN open collector output / Voltage output
- Line driver output



Pin No.	Function	Cable color
1	OUT A	Black
2	OUT B	White
3	OUT Z	Orange
4	+V	Brown
5	GND	Blue
6	F.G.	Shield

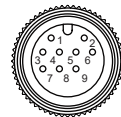

Pin No.	Function	Cable color
1	OUT A	Black
2	OUT A-bar	Red
3	+V	Brown
4	GND	Blue
5	OUT B	White
6	OUT B-bar	Gray
7	OUT Z	Orange
8	OUT Z-bar	Yellow
9	F.G.	Shield

- ※ F.G. (field ground): It should be grounded separately.

Incremental Ø58mm Shaft/Hollow Shaft/Blind Hollow Shaft Type

■ Dimensions

○ Shaft clamping type (SC)

(unit: mm)

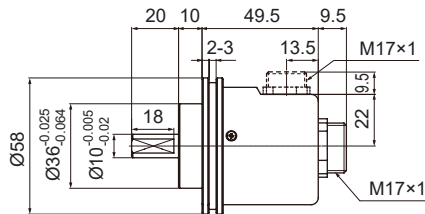
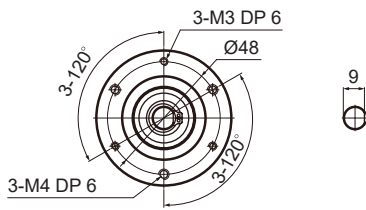
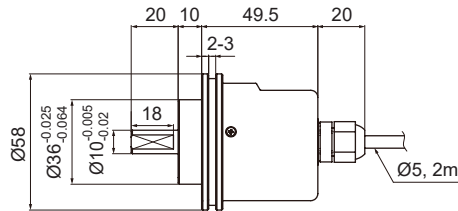
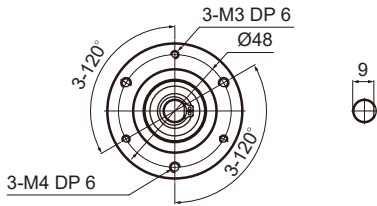

○ Shaft synchro type (SS)

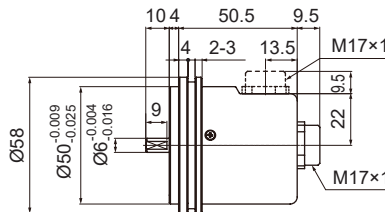
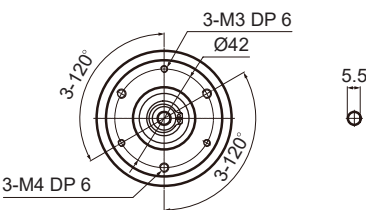
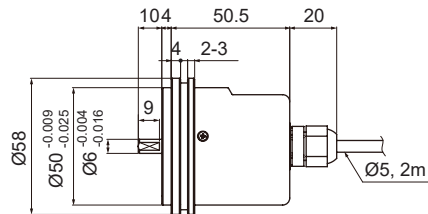
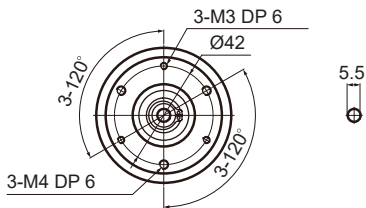

● Axial / Radial cable connector type

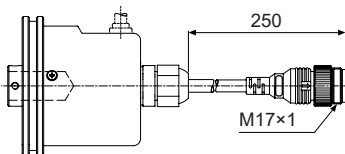

Cable for Axial/Radial cable connector type
 Ø5mm, 5-wire (line driver output: 8-wire),
 250mm, Shield cable

※Connector cable is sold separately and refer to page H-10 for specifications.

SENSORS
CONTROLLERS
MOTION DEVICES
OTHERS

(A) Photoelectric Sensors
(B) Fiber Optic Sensors
(C) Door/Area Sensors
(D) Vision Sensors
(E) Proximity Sensors
(F) Pressure Sensors
(G) Rotary Encoders
(H) Connectors/ Connector Cables/ Sensor Distribution Boxes/ Sockets

E58 Series

■ Dimensions

○ Hollow shaft type (H)

(unit: mm)

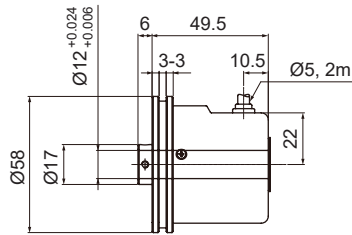
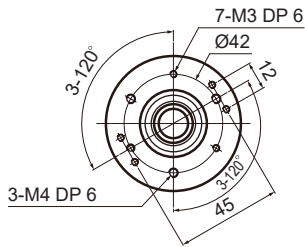

○ Blind hollow shaft type (HB)

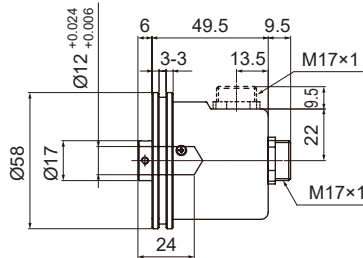
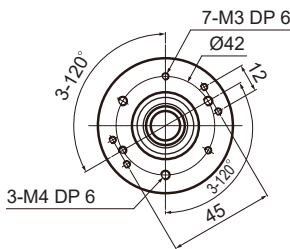
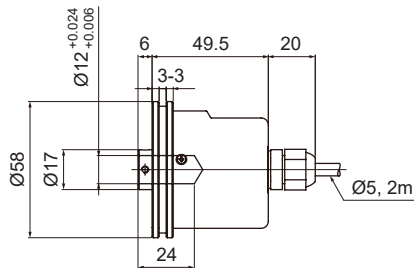
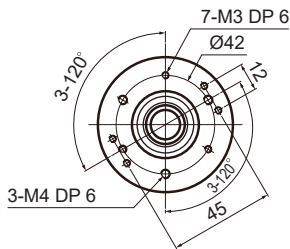

○ Coupling

● E58SC10

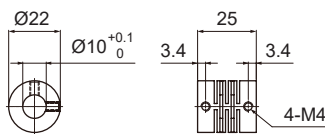

● E58SS6

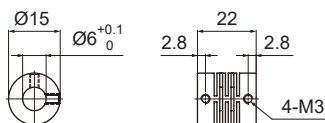

- Parallel misalignment: max. 0.25mm
- Angular misalignment: max. 5°
- End-play: max. 0.5mm

○ Bracket

● SC type

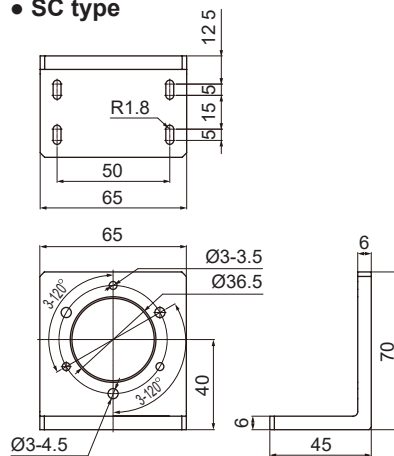

● SS type

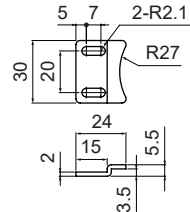

● H/HB type

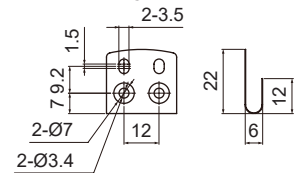

- ※Do not load overweight on the shaft.
- ※Do not put strong impact when insert a coupling into shaft. Failure to follow this instruction may result in product damage.
- ※Fix the unit or a coupling by a wrench under 0.15 N·m of torque.
- ※When you install this unit, if eccentricity and deflection angle are larger, it may shorten the life cycle of this unit.
- ※For parallel misalignment, angular misalignment, end-play terms, refer to page G-98.
- ※For flexible coupling (ERB series) information, refer to page G-91.

Incremental Sine Wave Ø58mm Shaft Type

Shaft Type Ø58mm Sine Wave Incremental Rotary Encoder

■ Specifications

Item		Shaft Type Ø58mm Sine Wave Incremental Rotary Encoder		
Model		E58S9.25-2048-10-A-5-R	E58S9.25-2048-10-A-5-S	
Revolution (PPR)		2,048		
Output phase		A, \bar{A} , B, \bar{B} , Z, \bar{Z} , C, \bar{C} , D, \bar{D} phase		
Phase difference of output		Phase difference between A and B: $\frac{T}{4} \pm \frac{T}{8}$ (T=1 cycle of A phase) Phase difference between C and D: 90°		
Electrical specification	Control output	Output type	OP Amp output	
		Output current	Max. 10mA	
		Output voltage	V_{p-p} : 0.5V±0.1V	
		DC offset	V_{DC} : 2.5V±0.3V	
	Max. response frequency		200kHz	
	Power supply		5VDC: ±5% (ripple P-P: max. 5%)	
	Current consumption		Max. 120mA (disconnection of the load)	
	Insulation resistance		Over 100MΩ (at 500VDC megger between all terminals and case)	
	Dielectric strength		750VAC 50/60Hz for 1 minute (between all terminals and case)	
	Connection		Axial cable type	Radial cable type
Mechanical specification	Starting torque		Max. 100gf·cm (0.0098N·m)	
	Moment of inertia		Max. 15g·cm ² (1.5×10 ⁻⁶ kg·m ²)	
	Shaft loading		Radial: 10kgf, Thrust: 2.5kgf	
	Max. allowable revolution		6,000rpm	
Shaft		Taper shaft Ø9.25mm, Taper 1:10		
Vibration		1.5mm amplitude at frequency of 10 to 55Hz in each X, Y, Z direction for 2 hours		
Shock		Approx. max. 100G		
Environment	Ambient temp.	-20 to 100°C, storage: -25 to 100°C		
	Ambient humi.	35 to 85%RH, storage: 35 to 90%RH		
Protection structure		IP50 (IEC standard)		
Cable		Ø6mm, 17-wire, 9m ^{※1} , Shield cable (AWG28, core diameter: 0.08mm, number of cores: 17, insulator out diameter: Ø 8mm)		
Accessory		M5×0.8 (50L), M5×0.8 (47L) wrench bolt		
Approval		CE		
Weight ^{※2}		Approx. 1 02kg (approx. 930g)		

※1: Option is 7m, 15m.

※2: The weight includes packaging. The weight in parenthesis in for unit only.

※Environment resistance is rated at no freezing or condensation.

SENSORS

CONTROLLERS

MOTION DEVICES

OTHERS

(A) Photoelectric Sensors

(B) Fiber Optic Sensors

(C) Door/Area Sensors

(D) Vision Sensors

(E) Proximity Sensors

(F) Pressure Sensors

(G) Rotary Encoders

(H) Connectors/ Connector Cables/ Sensor Distribution Boxes/ Sockets

E58 Series

Control Output Diagram

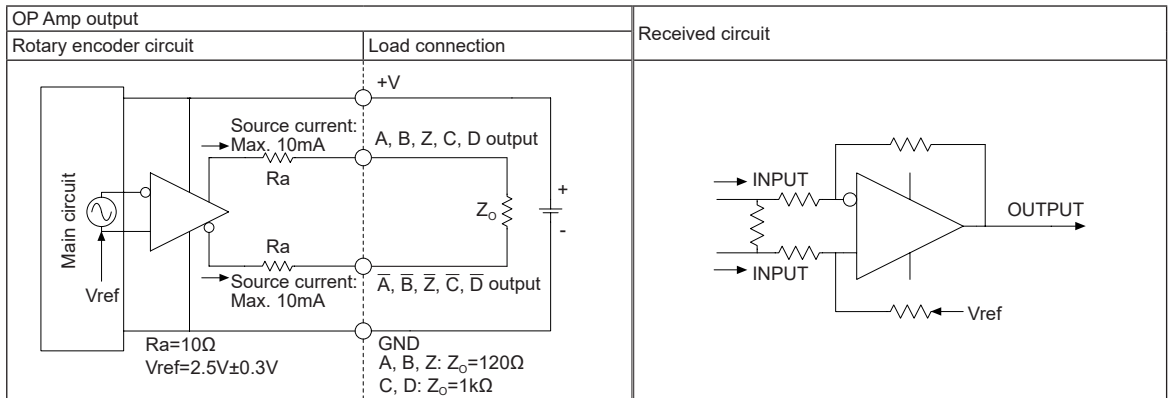

• All output circuits of A, \bar{A} , B, \bar{B} , Z, \bar{Z} , C, \bar{C} , D, \bar{D} phase are the same.

Output Waveforms

⊙ A, \bar{A} , B, \bar{B} , Z, \bar{Z} phase

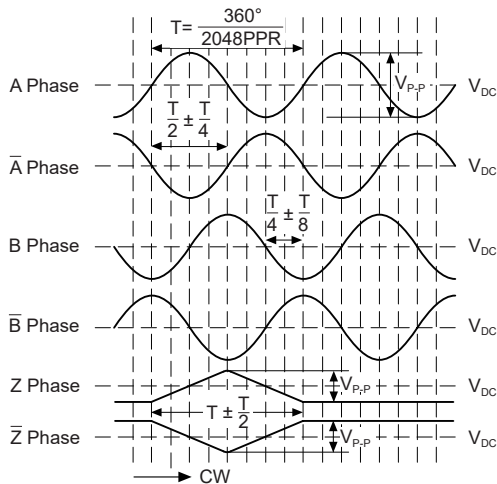

⊙ C, \bar{C} , D, \bar{D} phase

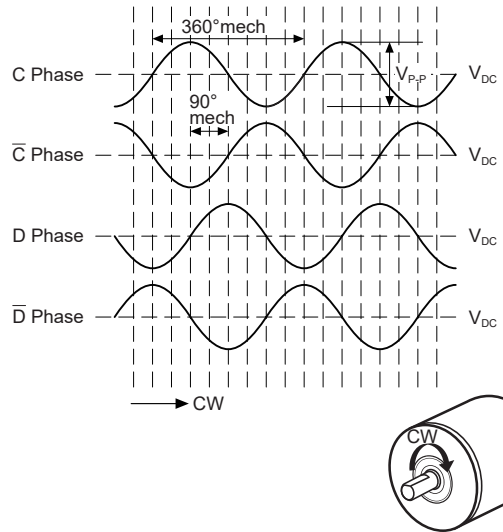

Connections

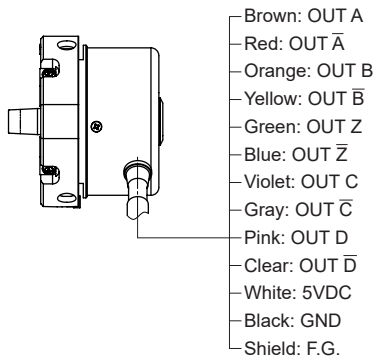

※ Unused wires must be insulated.
 ※ The metal case and shield cable of encoder should be grounded (F.G.).
 ※ The output circuit has the dedicated IC and be sure not to short-circuit when wiring the output cables.

Incremental Sine Wave Ø58mm Shaft Type

■ Dimensions

(unit: mm)

○ Axial cable type

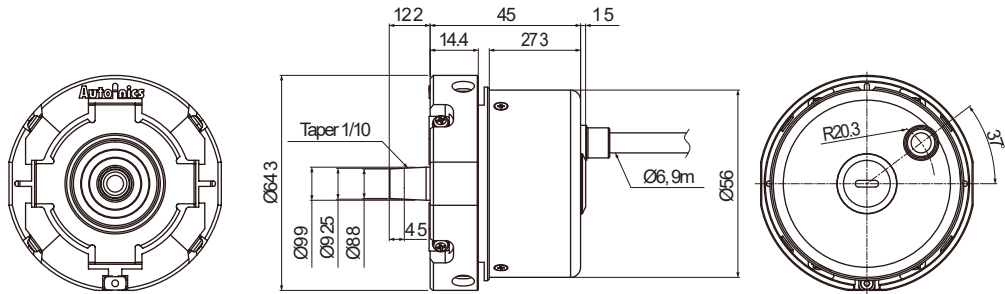

○ Radial cable type

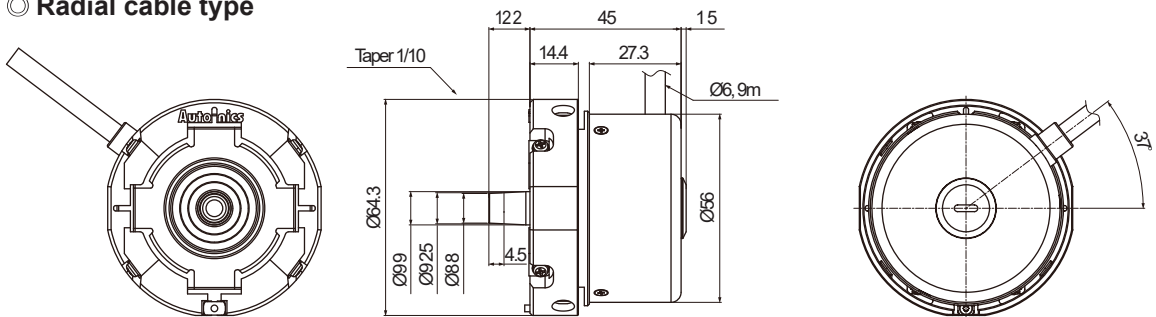

■ Installation

(unit: mm)

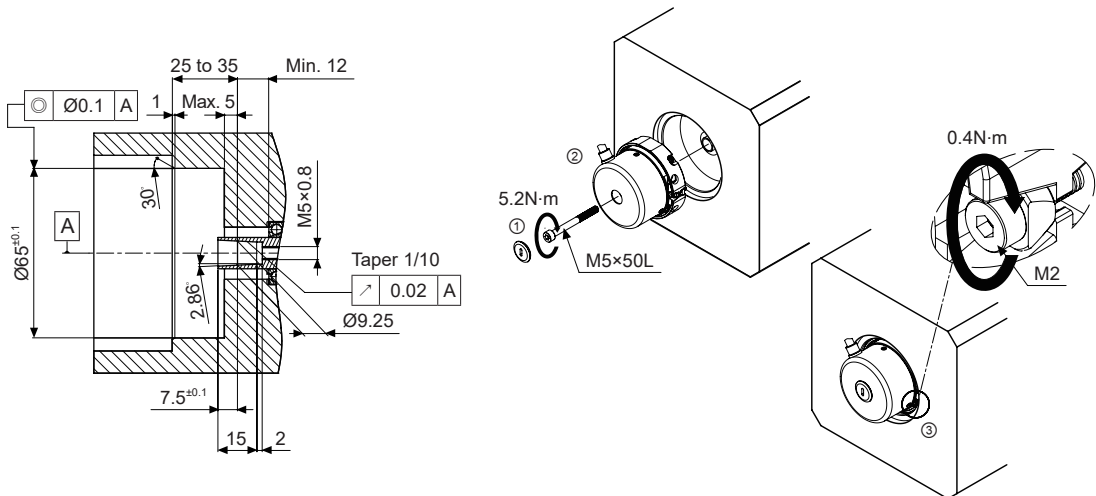

- ① Insert the M5×50L wrench bolt at rear of the E58S .
- ② Install the E58S on the device.
- ③ Adjust bracket size with M2 wrench.

SENSORS

CONTROLLERS

MOTION DEVICES

OTHERS

(A) Photoelectric Sensors

(B) Fiber Optic Sensors

(C) Door/Area Sensors

(D) Vision Sensors

(E) Proximity Sensors

(F) Pressure Sensors

(G) Rotary Encoders

(H) Connectors/ Connector Cables/ Sensor Distribution Boxes/ Sockets